

Part number:

**HYDROMA**

HYDRAULICKÉ SYSTÉMY

**HIDROMA  
SISTEMS**

UKŁADY HYDRAULICZNE

**HYDROMA**

ГИДРАВЛИЧЕСКИЕ СИСТЕМЫ

**LANTERNA Ø 250 PER MOTORE ELETTRICO GRANDEZZA 100-112**  
**FLANGE Ø 250 CONNECT EL. MOTOR FRAME 100-112**  
**LANTERNE Ø 250 POUR MOTEUR ÉLECTRIQUE TAILLE 100-112**  
**PUMPENTRÄGER 250 Ø FÜR EL. MOTOR 100-112 BAUGRÖÖE**

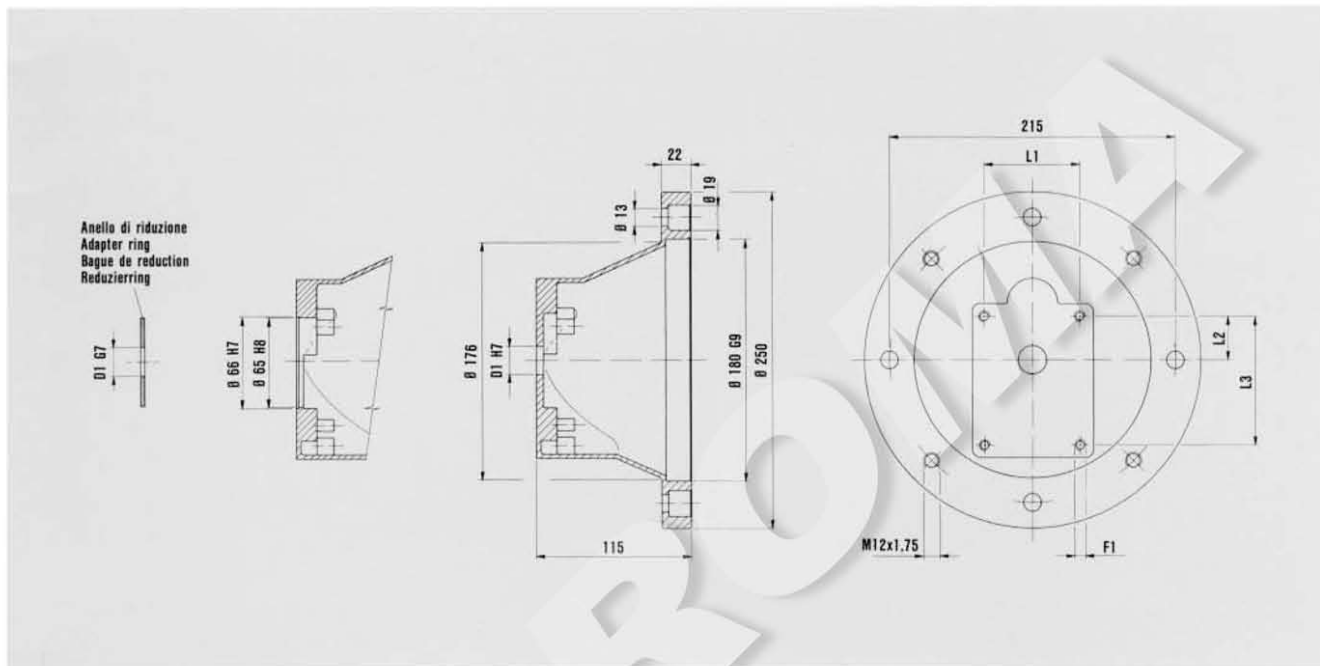

Hydr-App riferimenti Hydr-App references Hydr-App références Hydr-App Beziehungen		DIMENSIONI FLANGE FLANGE DIMENSIONS DIMENSIONS DES LANTERNES ABMESSUNGEN DER PUMPENTRÄGER							Giunti Elastici HE Flexible Couplings HE Accouplements Elastiques HE Drehelastische Kupplungen HE		
		Sigla Model-code Sigle Bestellzeichen	Matricola Part Number Maticulare Bestellnummer	D1	L1	L2	L3	F1			
Pumps	E. Motor										
1	100 ÷ 112	HL8/1L	30302500	25,4	52,4	26,3	72	M6	HE16		
1C		HL8L	30302700	30	56	24,5	73		HE17		
1M									HE18		
2		HL9L	30302600	36,5	71,5	32,35	96	M8	HE19		
2T									HE20		
ZB1		HLB13L	30302800	32	40	10,4	40	M6	HE109		
ZF2		<b>HLB17L</b>	<b>30303200</b>	80	72	34,5	100		HE111		
1CB		HLB14L	30302900	35	70	24	70		HE59		
2CB		HLB16L	30303700	50	75	21,5	75	M8	HE60		
(*) 1			HL8/1LCC	15050002	25,4	52,4	26,3	72	M6	HE16	
(*) 1C			HL8LCC	15050004	30	56	24,5	73		HE17	
(*) 1M										HE18	
(*) 2			HL9LCC	15050003	36,5	71,5	32,35	96		M8	HE19
(*) 2T										HE20	

(\*) LANTERNE CON ANELLO DI RIDUZIONE  
 (\*) FLANGE WITH ADAPTER RING  
 (\*) LANTERNE AVEC BAGUE DE REDUCTION  
 (\*) PUMPENTRÄGER MIT REDUZIERRING