

Part number:

**HYDROMA**

HYDRAULICKÉ SYSTÉMY

**HIDROMA  
SYSTEMS**

UKŁADY HYDRAULICZNE

**HYDROMA**

ГИДРАВЛИЧЕСКИЕ СИСТЕМЫ

Variable displacement vane pump with horse power limiter compensator device

# PHPK

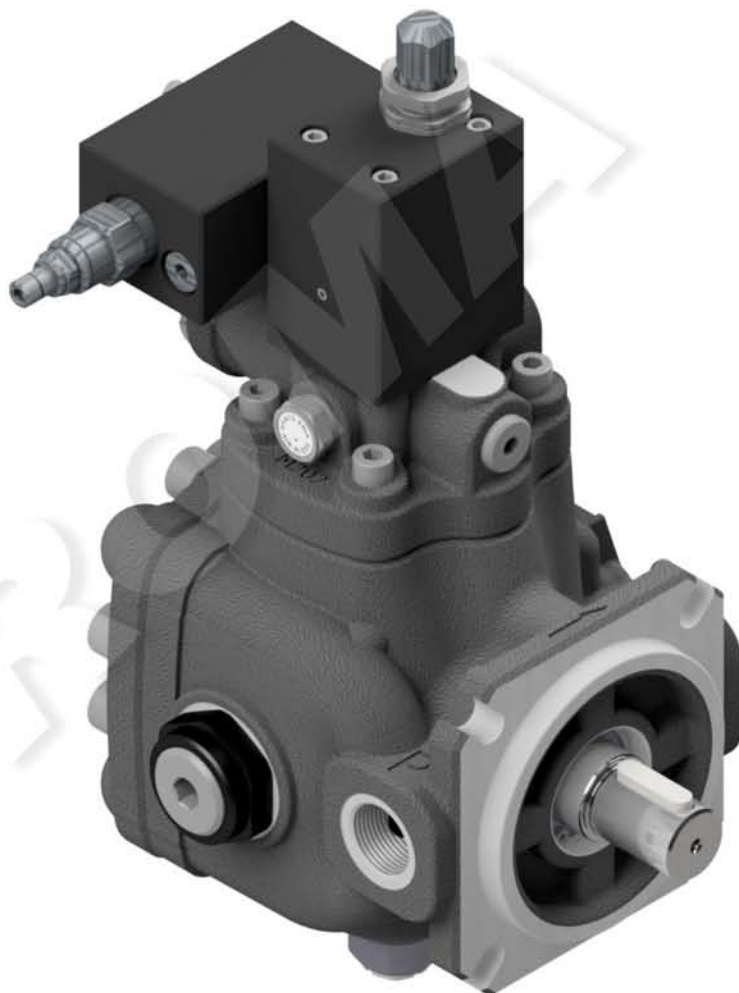

Series Name	Displacement [cm <sup>3</sup> /r]	Flow rate at 1450rpm [l/min]	Max. pressure [bar]
01 PHPK 1-20	20	29	180
01 PHPK 1-25	25	36	180
01 PHPK 1-32	32	47	180
01 PHPK 2-40	40	58	180
01 PHPK 2-50	50	73	180
01 PHPK 2-63	63	92	180
01 PHPK 3-80	80	116	180
01 PHPK 3-100	100	145	180
01 PHPK 3-120	120	174	180

## General description

Berarma is continually looking for solutions which would allow it to offer increasingly advanced systems and components to its users. Therefore, Berarma has designed a Horse Power Limiter control device for its PHPK type variable displacement vane pumps. This device allows the optimum usage of absorbed power. The operating principle is based on maintaining the flow-pressure product ( $q \times p$ ) practically constant, so that when the pressure increases, the flow decreases and vice versa, according to a characteristic hyperbolic-type curve.

Berarma PHPK pumps are especially suited for those systems with a work cycle consisting of two operating phases:

- a first phase characterized by a quick approach at low pressure
- a second phase characterized by low speed and high pressure (e.g. forming, drawing, blanking presses, etc.)

In this way, it is possible to set up a system using only one pump, where previously two pumps were required, resulting in obvious cost savings.

The PHPK series pumps combines the characteristics of other Berarma variable displacement vane pumps with

- Silent running
- High efficiency
- Long working life
- Economy and simplification of hydraulic system
- Modular design
- Energy saving

What makes the Berarma PHPK series pumps very interesting for the market?

- Dual inlet and outlet channels in the internal pump cartridge
- Dual axial hydrostatic balancing on the distribution plates
- Wear reduction of the internal pump cartridge parts
- Innovative shapes and design
- 180bar working pressure

## How to order

The PHPK pump can be ordered in two different ways:

- 1) starting from the power value of the motor (contact Berarma technical service to find out the available power values) and from the maximum working pressure, thus obtaining a characteristic curve making it possible for the pump to optimize installed power usage;
- 2) starting from the minimum flow value to be obtained at the previously defined maximum working pressure. In this way the motor power and the characteristic curve are determined from defined operating conditions.

Starting from the motor power value and maximum working pressure value indicated in the ordering code, Berarma performs the bench calibration of the constant power device so that the actual characteristic curve of the pump approximates the theoretical hyperbolic curve (see image below).

It is possible to change the power calibration by the user by strictly following the instructions in the related procedure available on the website and / or by contacting the Berarma technical service.

Pump absorbed power can be calculated using the following formula:

$$\text{Power [kW]} = \frac{\text{pressure [bar]} \times \text{flow [l/min]}}{600 \times 0.88}$$

where 0.88 = total efficiency value purely indicative

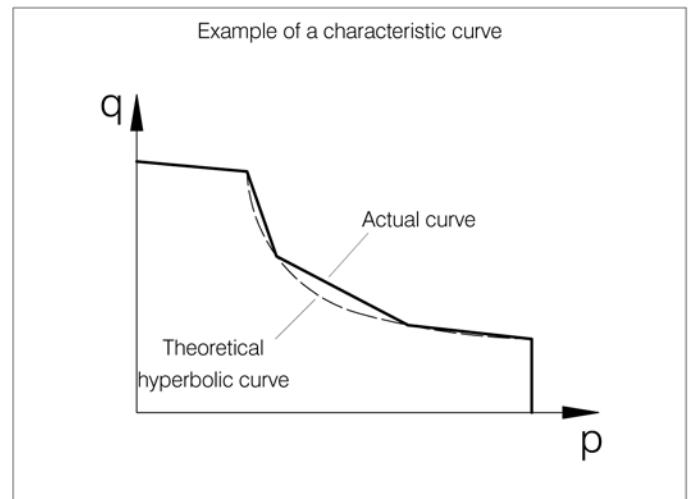

## Technical data

Size	1	2	3
Geometric displacement according to ISO 3662 (cm <sup>3</sup> /r)	20 ÷ 25 ÷ 32	40 ÷ 50 ÷ 63	80 ÷ 100 ÷ 120
Actual displacement (cm <sup>3</sup> /r) Due to manufacturing tolerances, the value can vary by approx. ±3%	21 ÷ 26 ÷ 33	42 ÷ 51 ÷ 63	80 ÷ 100 ÷ 123
Maximum working pressure (bar) Pressure peak exceeding 30% of the maximum operating pressure must be eliminated by adopting the appropriate measures	180 The maximum achievable pressure depends on the required power setting		
Permitted maximum drain port pressure (bar)	1		
Inlet pressure (bar)	0.8 ÷ 1.5 absolute		
Speed range (rpm)	800 ÷ 1800	800 ÷ 1500 1800 allowed with max. pressure 160bar	
Rotation direction	<b>R:</b> right (clockwise) viewed from shaft end		
Load on drive shaft	NO RADIAL OR AXIAL LOADS ALLOWED		
Hydraulic fluid	HM hydraulic oil according to ISO 6743/4 ÷ HLP according to DIN 51524/2 for other fluids please contact Berarma technical sales service		
Viscosity range (cSt, mm <sup>2</sup> /s)	22 ÷ 68 at operating temperature		
Starting viscosity under full flow conditions (cSt, mm <sup>2</sup> /s)	400 max.		
Viscosity index (ISO 2909)	100 min.		
Inlet fluid temperature range (°C)	+15 / +60 ÷ pay attention to viscosity range		
Maximum acceptable fluid contamination level	20/18/15 according to ISO 4406/99 CLASS 9 according to NAS 1638		
Recommended fluid contamination level for a longer pump working life	18/16/13 according to ISO 4406/99 CLASS 7 according to NAS 1638		
Moment of inertia (kgm <sup>2</sup> )	0.0005	0.00909	0.015
	Weight single pump (kg)		
Standard control	23	48.5	59
PCS002 control	23.2	48.8	59.2
PCS003 control	22.7	48.3	58.8
For further information and/or different operating conditions please contact Berarma technical sales service			

## Installation and start-up

For the installation and start-up of Berarma pumps please refer to related **Document INSTALLATION AND START-UP INSTRUCTIONS** available on our website and provided in hard copy with every pump supplied.

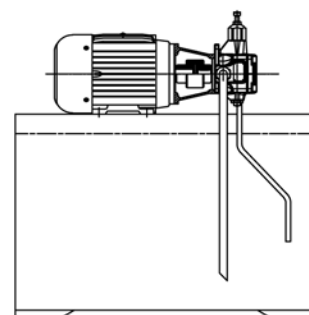

## Ordering code

Series Name	Size Displacement	Flange	Pressure setting	Rotation	Seals	Options	Pressure control	Power setting	Max. Pressure
<b>01 PHPK</b>	<b>2 – 50</b>	<b>F</b>	<b>H</b>	<b>R</b>	<b>M</b>	<b>A</b>	<b>PCS003</b>	<b>7.5</b>	<b>180</b>

Code	Size	Displacement cm³/r
<b>1 – 20</b>	1	20
<b>1 – 25</b>	1	25
<b>1 – 32</b>	1	32
<b>2 – 40</b>	2	40
<b>2 – 50</b>	2	50
<b>2 – 63</b>	2	63
<b>3 – 80</b>	3	80
<b>3 – 100</b>	3	100
<b>3 – 120</b>	3	120

Code	Flange	Ports
<b>F</b>	ISO 3019/2 4 holes	Gas BSP SAE 3000

Code	Pressure setting (bar)
<b>H</b>	180 depends on power setting

Code	Rotation direction
<b>R</b>	Right (CW) viewed from shaft

Code	Seals
<b>M</b>	NBR
<b>E</b>	FPM – Viton

Code	Option
/	Omit for no option
<b>A</b>	Thru drive shaft for combined pumps

Code	Pressure control
/	Single stage of pressure
<b>PCS002</b>	Single stage of pressure with remote pressure control
<b>PCS003</b>	Two stages of pressure, one with fixed setting at the minimum pressure

Code	Power setting
<b>kW</b>	Indicate the pump setting power value

Code	Maximum pressure
<b>bar</b>	Indicate the pump setting maximum working pressure value

**Overall dimensions**

01 PHPK 1-(20-25-32) – Single stage of pressure

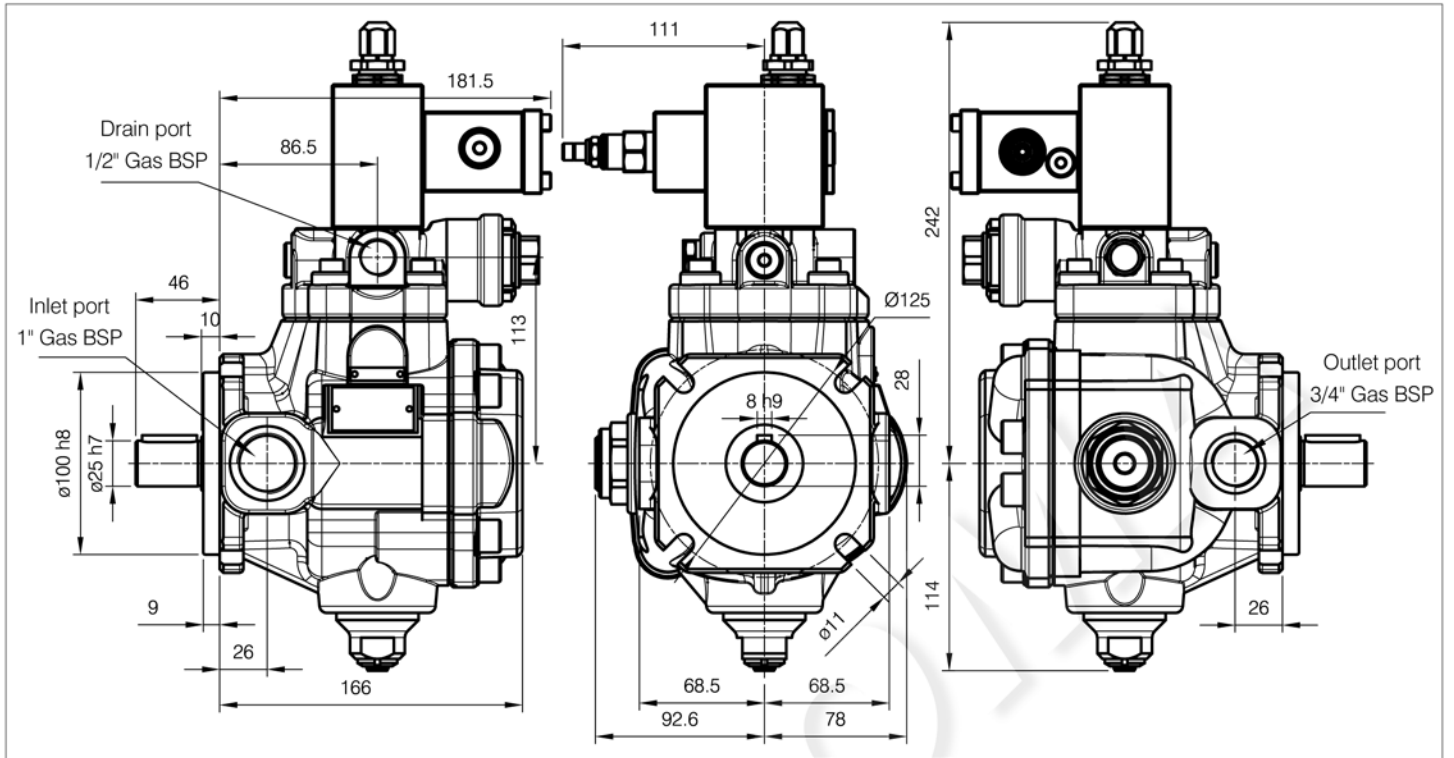

01 PHPK 1-(20-25-32) + Option "A"  
Single stage of pressure

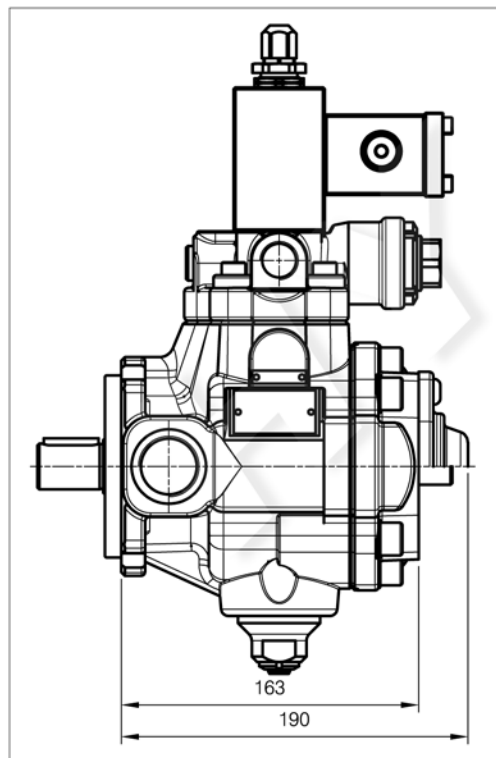

01 PHPK 1-(20-25-32)  
PCS002 pressure control

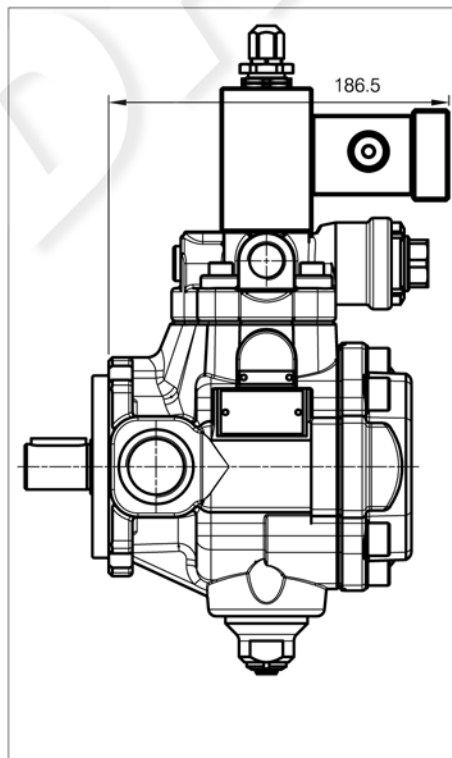

01 PHPK 1-(20-25-32)  
PCS003 pressure control

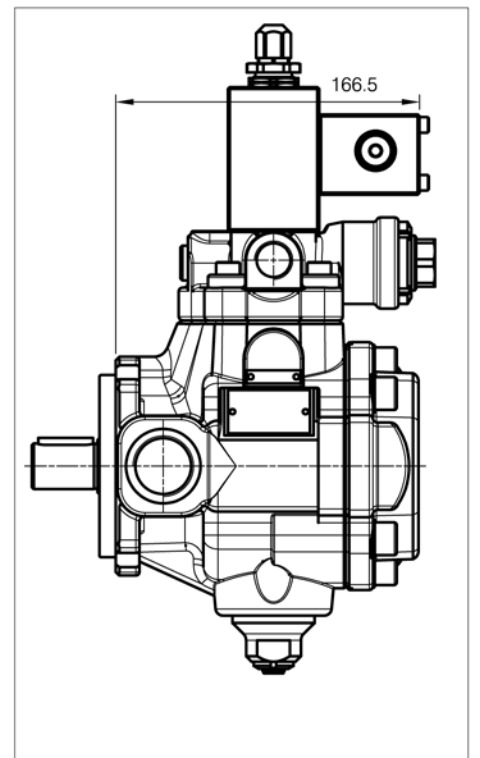

For information, please refer to related **Catalog COUPLINGS and ACCESSORIES**

**Overall dimensions**

**01 PHPK 2-(40-50-63) – Single stage of pressure**

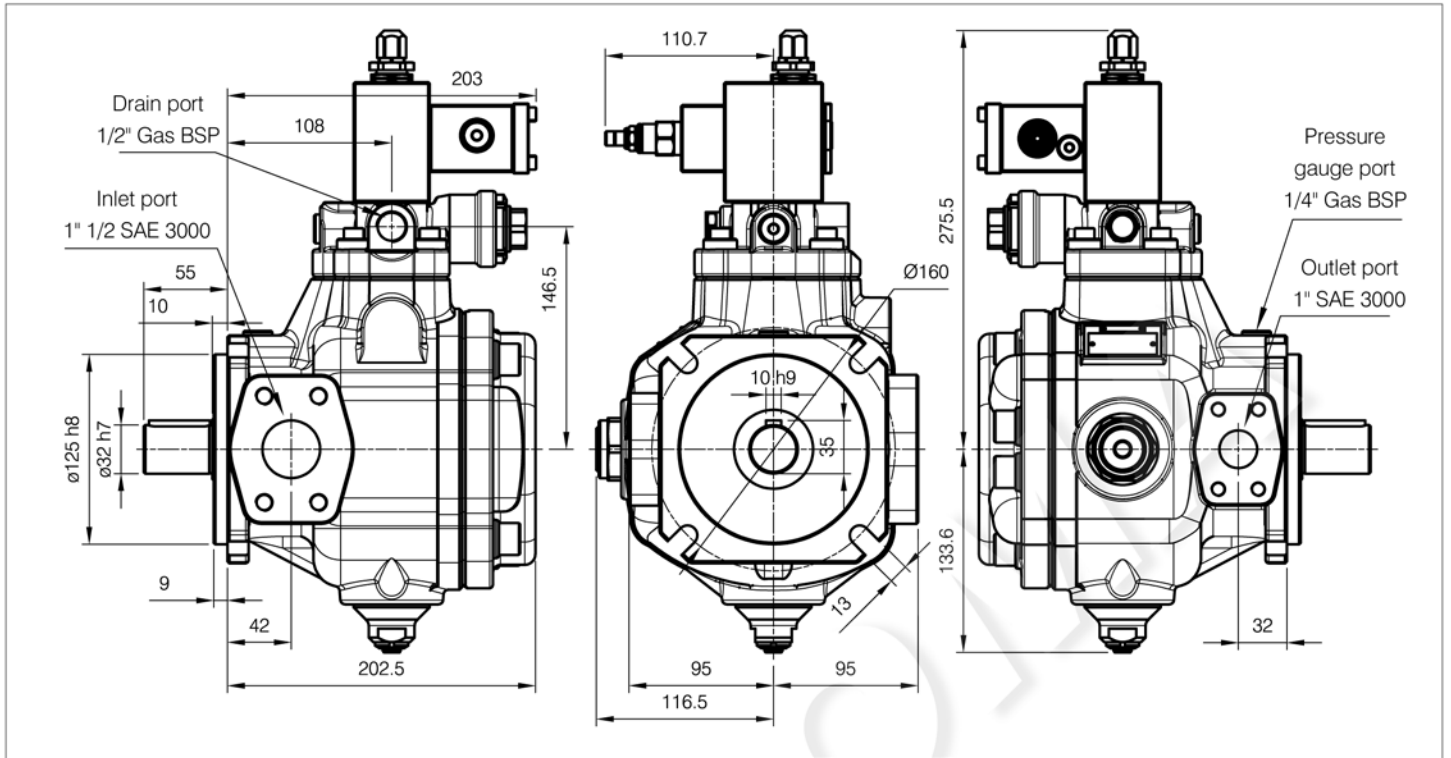

**01 PHPK 2-(40-50-63) + Option "A"**  
Single stage of pressure

**01 PHPK 2-(40-50-63)**  
PCS002 pressure control

**01 PHPK 2-(40-50-63)**  
PCS003 pressure control

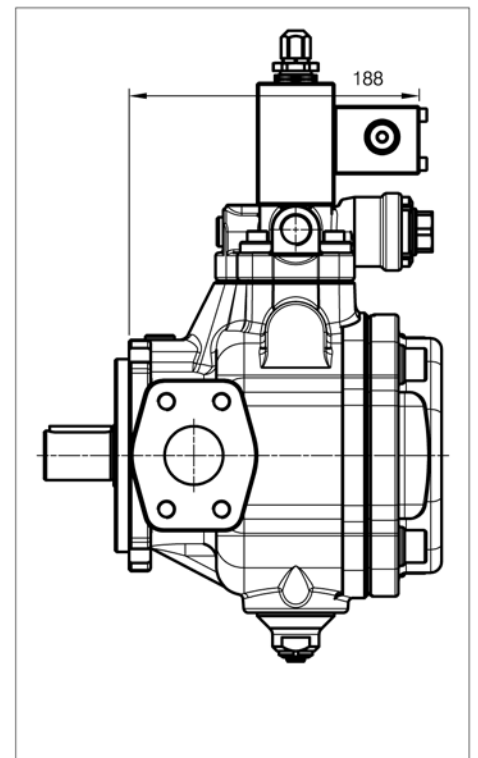
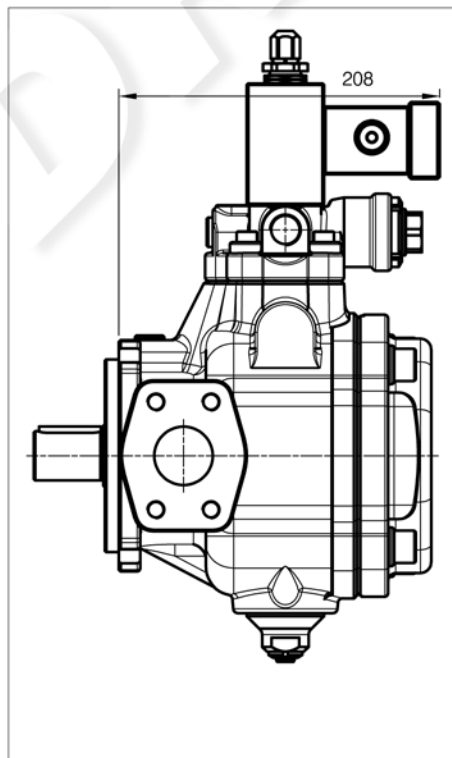
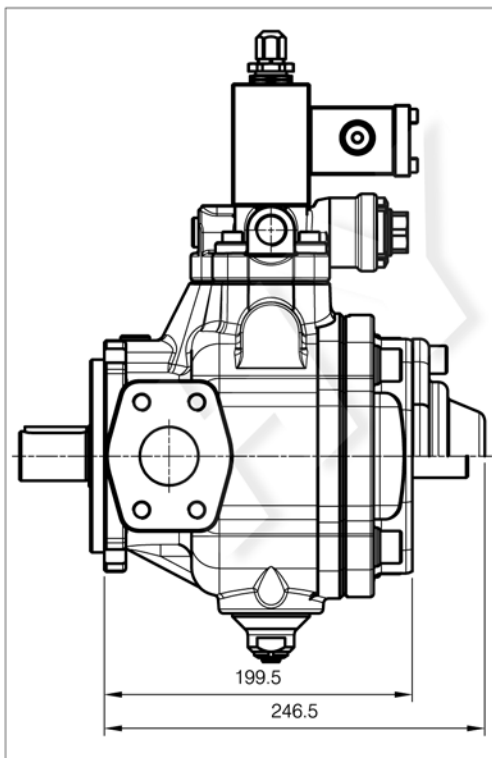

For information, please refer to related **Catalog COUPLINGS and ACCESSORIES**

**Overall dimensions**

**01 PHPK 3-(80-100-120) – Single stage of pressure**

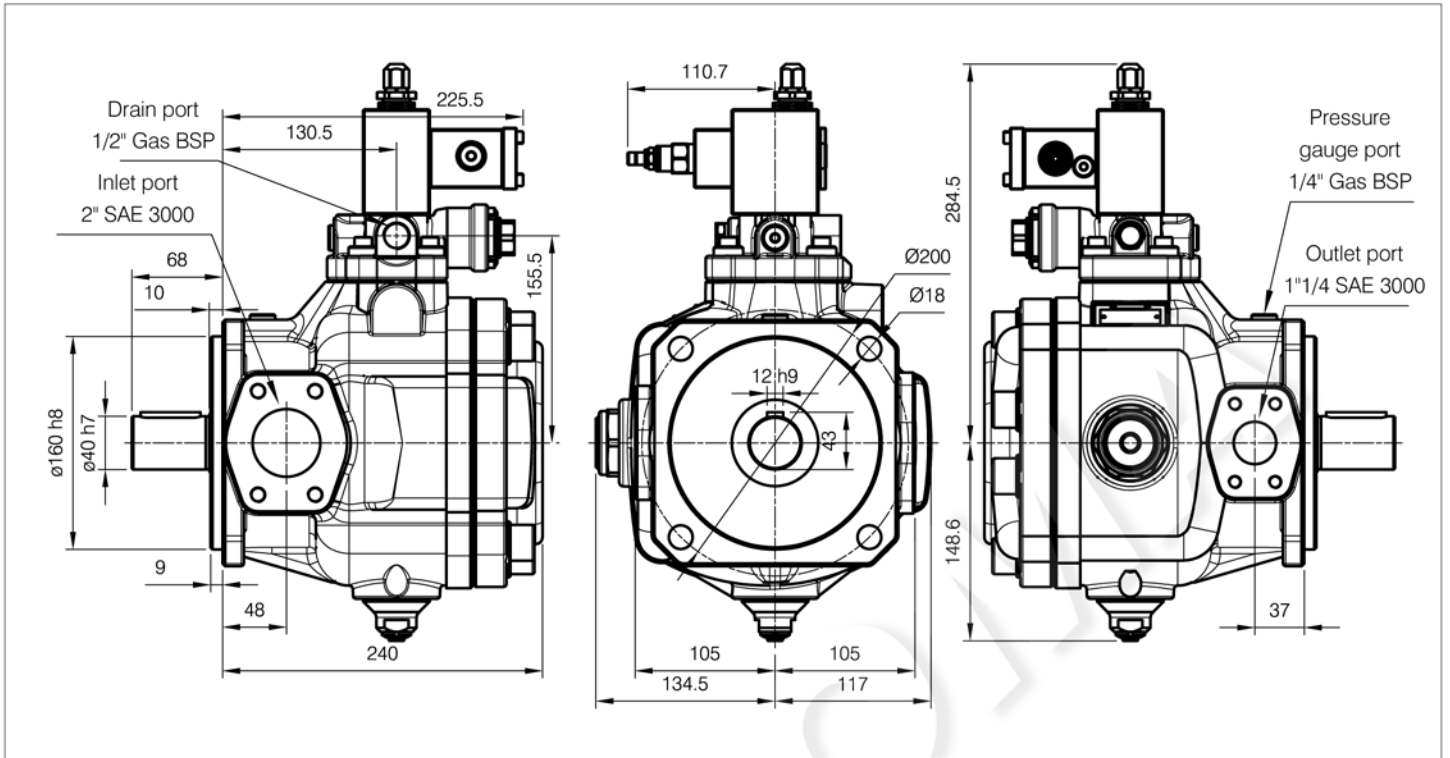

**01 PHPK 3-(80-100-120) + Option "A"**  
Single stage of pressure

**01 PHPK 3-(80-100-120)**  
PCS002 pressure control

**01 PHPK 3-(80-100-120)**  
PCS003 pressure control

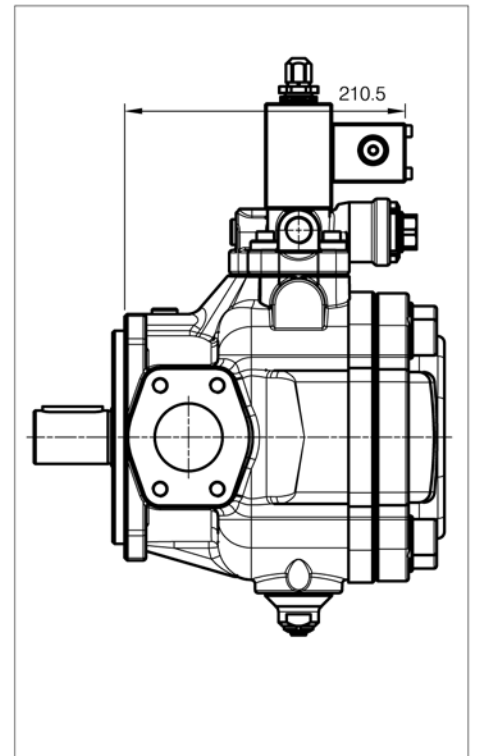
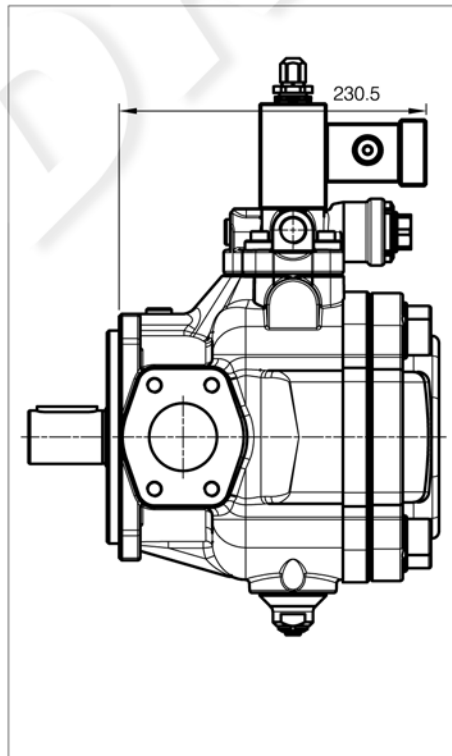
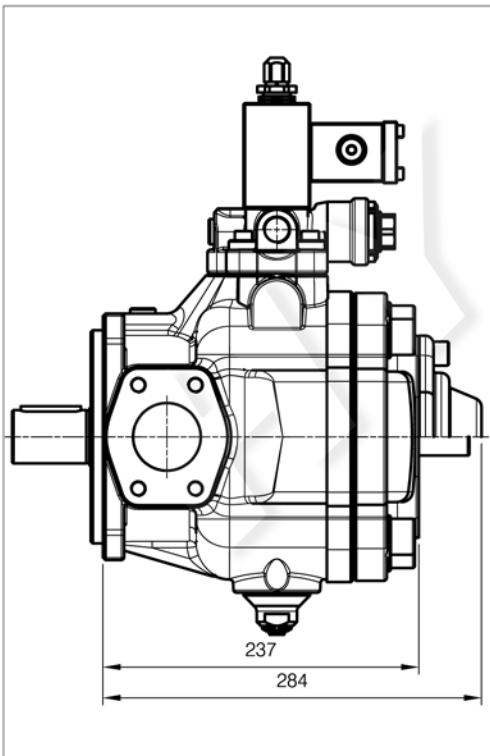

For information, please refer to related **Catalog COUPLINGS and ACCESSORIES**

## Pressure controls

### Single stage of pressure

This standard control enables the pump displacement to be adjusted (until zero flow setting condition) according to the flow rate required by the hydraulic system, keeping the horse power under the limit set on the compensator device according to the value defined in the order.  
The pressure value setting of the compensator device is adjusted by means of the pressure setting screw and locked using the locknut.

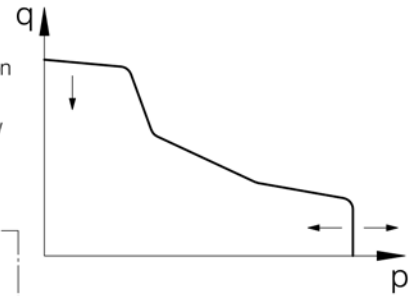
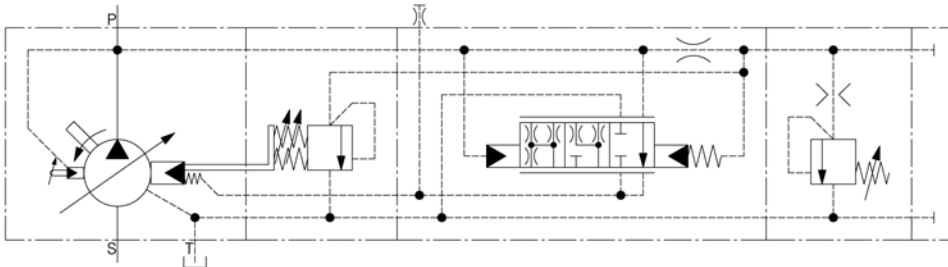

### PCS002 - Single stage of pressure with remote pressure control

The function of this control is the same as the standard control function with the possibility of adjusting the working pressure by means of an additional maximum pressure relief valve (**not supplied**) installed in a remote position, far from the pump.  
Control performances depends on the additional valve type and on its distance from the pump.  
To obtain the best performance, it is recommended to use maximum pressure relief valves with flow rates from 2 to 5 l / min and not to exceed 5 meters of pipe length.

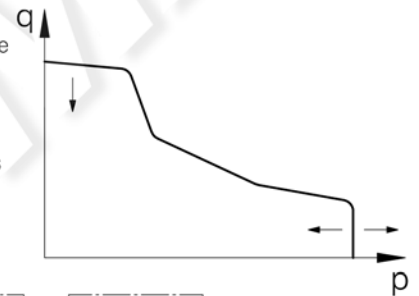
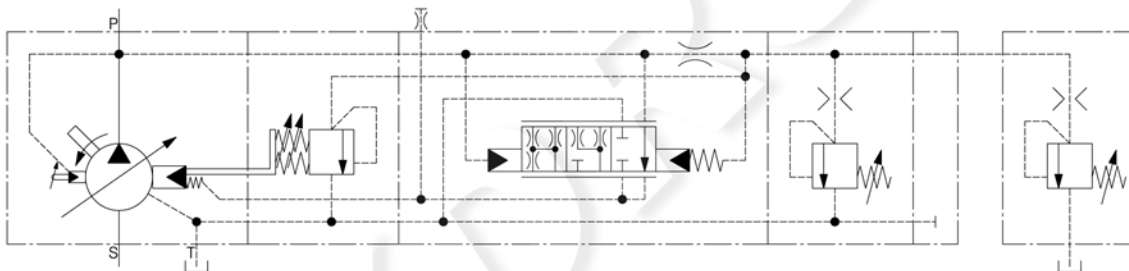

### PCS003 - Two stages of pressure, one with fixed setting at the minimum pressure

The function of this control is the same as the standard control with the possibility to mount a directional control valve ISO 4401-03 (CETOP 03 - NG6) (**not supplied**) on the top of the compensator in order to switch between two working pressure levels, one of which is fixed at the minimum pressure that depend from the horse power limiter setting.  
Control performance depends on the type of additional directional control valve.

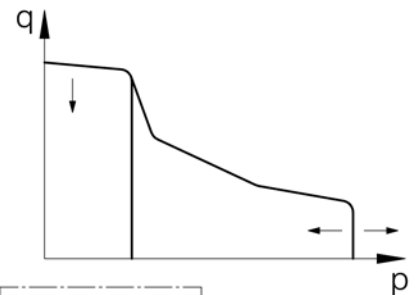
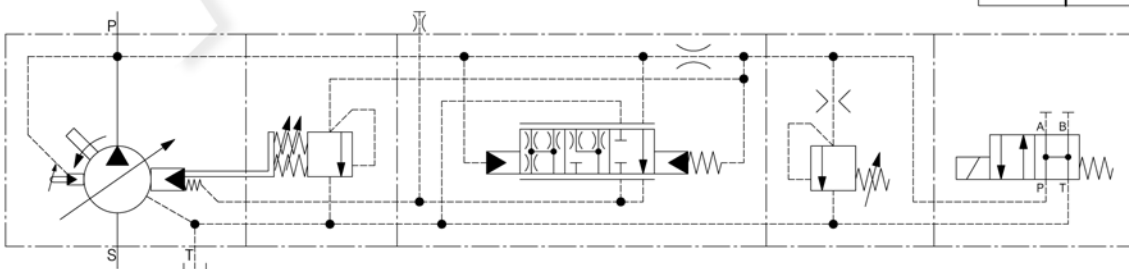



## Settings

### Pressure

All Berarma PHPK pumps are equipped with a hydraulic pressure adjustment device with horse power limiter that allow to adjust the maximum working pressure of the pump. By screwing clockwise, the pressure increases.

### Warning

Do not go out of the pressure setting range.

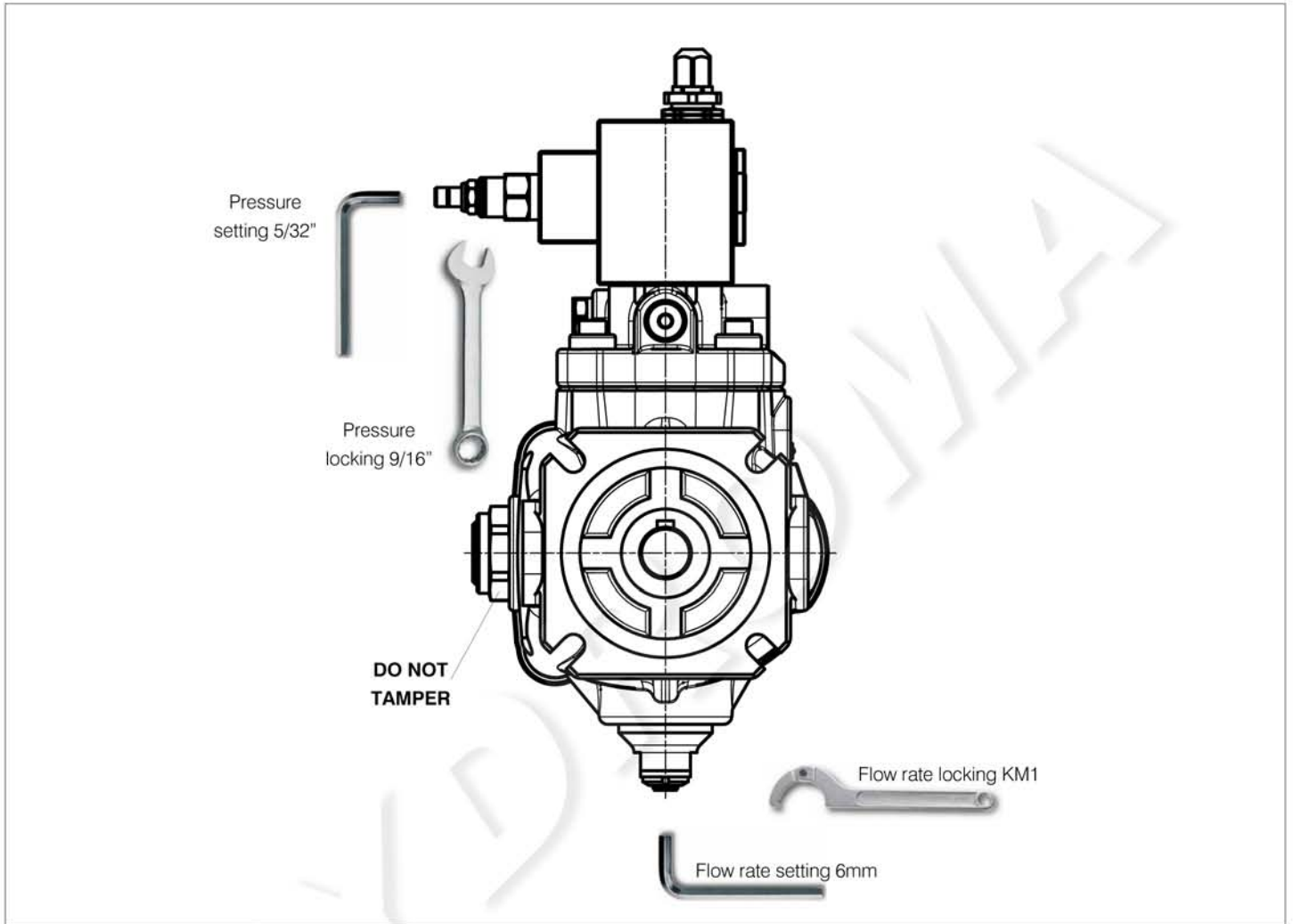

### Flow rate

All Berarma pumps are equipped with a flow regulator device that allow the mechanical reduction of the maximum pump displacement compared to the nominal value. By screwing clockwise, the flow rate decreases.

### Warning

If the flow regulator device is set to less than 50% of the nominal displacement, the pump can only start on condition that the system and pump are completely filled with fluid.

Pump type	Actual displacement (cm <sup>3</sup> /r)	Reduced displacement by screw turn (cm <sup>3</sup> /r)	Minimum displacement (cm <sup>3</sup> /r)
01 PHPK 1 - <b>20</b>	21	10	9.5
01 PHPK 1 - <b>25</b>	26	10	15
01 PHPK 1 - <b>32</b>	33	10	19
01 PHPK 2 - <b>40</b>	42	16	27.5
01 PHPK 2 - <b>50</b>	51	16	35.5
01 PHPK 2 - <b>63</b>	63	16	43.5
01 PHPK 3 - <b>80</b>	80	16	63
01 PHPK 3 - <b>100</b>	100	16	80
01 PHPK 3 - <b>120</b>	120	16	100

Indicative values influenced by manufacturing tolerances

## Accessories

Electric motors with special flange and hollow shaft for direct coupling with Berarma pumps size 05 and 1.  
For information, please refer to related **GMP Catalog**

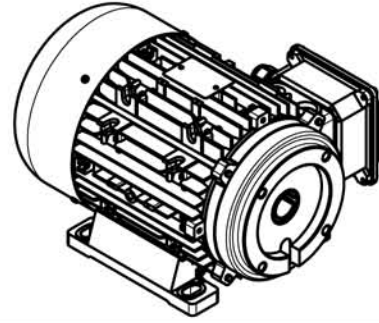

Non return valves integrated on SAE flange, ideal to be installed on Berarma Berarma pump size 2 and 3 outlet port or for installation on hydraulic systems.  
For information, please refer to related **NRV Catalog**

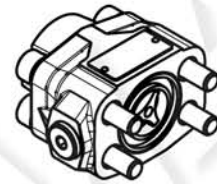

Coupling unit that allow to arrange combined pumps between Berarma pumps or the main other types of pump available on the fluid power market.  
For information, please refer to related **COUPLINGS and ACCESSORIES Catalog**

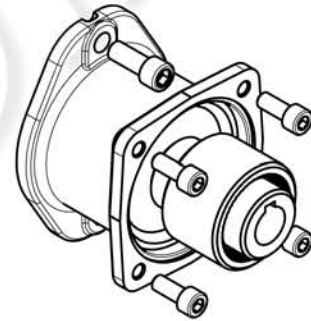

SAE 3000 flanges ideal to be installed on Berarma pump size 2 and 3 inlet and outlet ports.  
For information, please refer to related **COUPLINGS and ACCESSORIES Catalog**

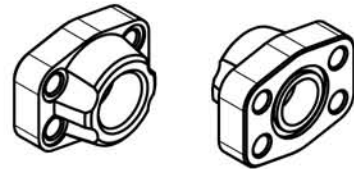

### Warning

All Berarma pumps have been carefully checked during manufacture and subjected to testing cycles before shipment. To achieve optimum performance, avoid problems and maintain the warranty, the installation instructions, enclosed with each pump supplied, must be strictly observed.

### Notes

Before selection and/or use of any Berarma product, it is important that the purchaser carefully analyses all aspects of its application and reviews the information in the current Berarma technical sales documents. Due to the many different operating conditions and applications for Berarma products, the purchaser, through their own analysis and testing, is solely responsible for making the final selection of the products and assuring that all performance and safety requirements are met. Berarma S.r.l. accepts no responsibility for any editing mistakes in this catalogue. Berarma S.r.l. reserves the right to modify the products and data contained in this catalogue at any time and without prior notice.