

Part number:

009-10147a

HYDROMA

HYDRAULICKÉ SYSTÉMY

**HIDROMA
SISTEMS**

UKŁADY HYDRAULICZNE

HYDROMA

ГИДРАВЛИЧЕСКИЕ СИСТЕМЫ

Tipo / Type

FPR C- *- *- *

Sez./Section

D

Valvola di ritegno unidirezionale, versione cartuccia
Check valve, cartridge version

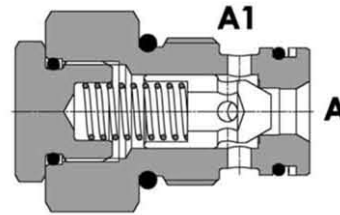
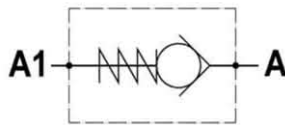

SPECIFICHE TECNICHE

Materiali: corpo in acciaio. L'otturatore conico guidato è in acciaio trattato termicamente. La superficie esterna è protetta mediante zincatura.

Portata: fino a 70 l/min

Pressione max.: 350 bar

Pressione di apertura: standard 0,5 bar, a richiesta 2,5-5-10 bar

TECHNICAL SPECIFICATIONS

Materials: body is steel made. Guided poppet is in hardened steel. External surface is zinc plated.

Rated flow: up to 70 l/min

Max. pressure: 350 bar, see data sheet

Cracking pressure: 0.5 bar standard, 2.5-5-10 bar on request

DIAGRAMMA PERDITE DI CARICO - PRESSURE DROP CURVES

Viscosità olio 24 mm²/sec. (3,5 °E)
Temperatura 50 °C

Oil viscosity 24 mm²/sec. (3,5 °E)
Temperature 50 °C

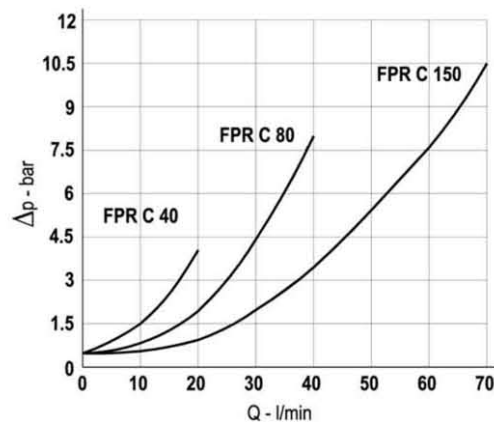

Part number:

009-10147b

HYDROMA

HYDRAULICKÉ SYSTÉMY

**HIDROMA
SYSTEMS**

UKŁADY HYDRAULICZNE

HYDROMA

ГИДРАВЛИЧЕСКИЕ СИСТЕМЫ

Tipo / Type

FPR C- *- *- *

Sez./Section

D

Valvola di ritegno unidirezionale, versione cartuccia
Check valve, cartridge version

COPPIA DI SERRAGGIO - INSTALLATION TORQUE

Tipo - Type	Nm
FPR C 40	50 - 60
FPR C 80	50 - 60
FPR C 150	110 - 120

CAVITA' - CAVITY

Tipo - Type	
FPR C 40	22221
FPR C 80	22222
FPR C 150	22331

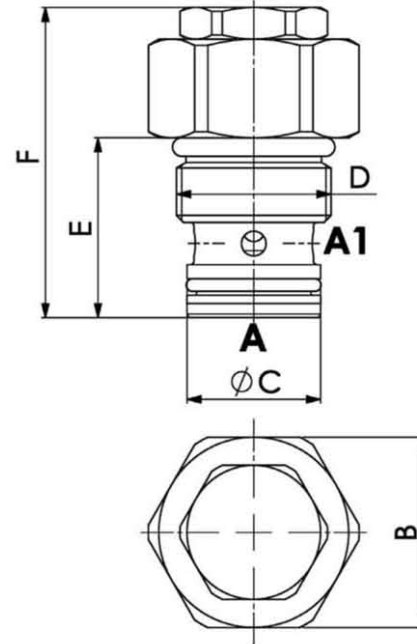

TIPO TYPE	PORTATA MAX. MAX. FLOW	PRESSIONE MAX. MAX. PRESSURE	B	ØC	D	E	F	PESO WEIGHT
	l/min	bar						Kg
FPR C 40	20	350	27	19	M22x1.5	25.5	44	0.090
FPR C 80	40	350	27	19	M22x1.5	35.5	50	0.095
FPR C 150	70	300	38	28	M33x2	43	60	0.230

ESEMPIO DI ORDINAZIONE - ORDERING CODE EXAMPLE

