

Part number:

009-10222a

HYDROMA

HYDRAULICKÉ SYSTÉMY

**HIDROMA
SYSTEMS**

UKŁADY HYDRAULICZNE

HYDROMA

ГИДРАВЛИЧЕСКИЕ СИСТЕМЫ

Tipo/Type

FPS L-*.*.*.*.*

Sez/Section

E

Valvola di blocco pilotata semplice, montaggio in linea
Single pilot operated check valve, line mounted

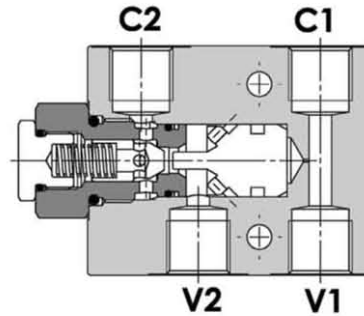
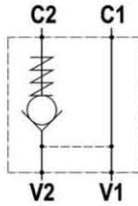

SPECIFICHE TECNICHE

Materiali: corpo in alluminio (a richiesta in acciaio). I componenti interni sono in acciaio trattato termicamente e rettificati.

Portata max.: 85 l/min

Pressione max.: vedere tabella pag. 02

Pressione di apertura: standard 2,5 bar, a richiesta 5-10 bar

TECHNICAL SPECIFICATIONS

Materials: body is in aluminium (steel on request). Internal parts are in hardened and ground steel.

Rated flow: 85 l/min

Max. pressure: see data sheet page 02

Cracking pressure: 2.5 bar standard, 5-10 bar on request

DIAGRAMMA PERDITE DI CARICO - PRESSURE DROP CURVES

Viscosità olio 24 mm²/sec. (3,5 °E)
Temperatura 50 °C

Oil viscosity 24 mm²/sec. (3,5 °E)
Temperature 50 °C

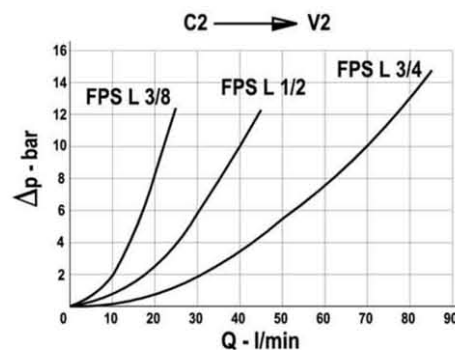
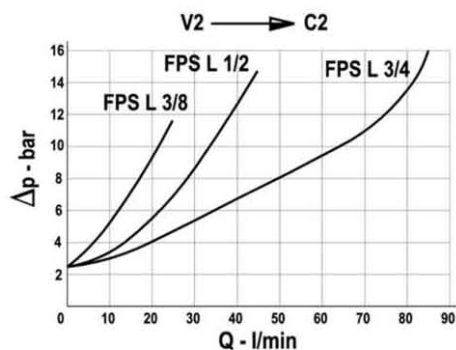

Part number:

009-10222b

HYDROMA

HYDRAULICKÉ SYSTÉMY

**HIDROMA
SYSTEMS**

UKŁADY HYDRAULICZNE

HYDROMA

ГИДРАВЛИЧЕСКИЕ СИСТЕМЫ

Tipo/Type

FPS L-*.*.*.*.*

Sez./Section

E

Valvola di blocco pilotata semplice, montaggio in linea
Single pilot operated check valve, line mounted

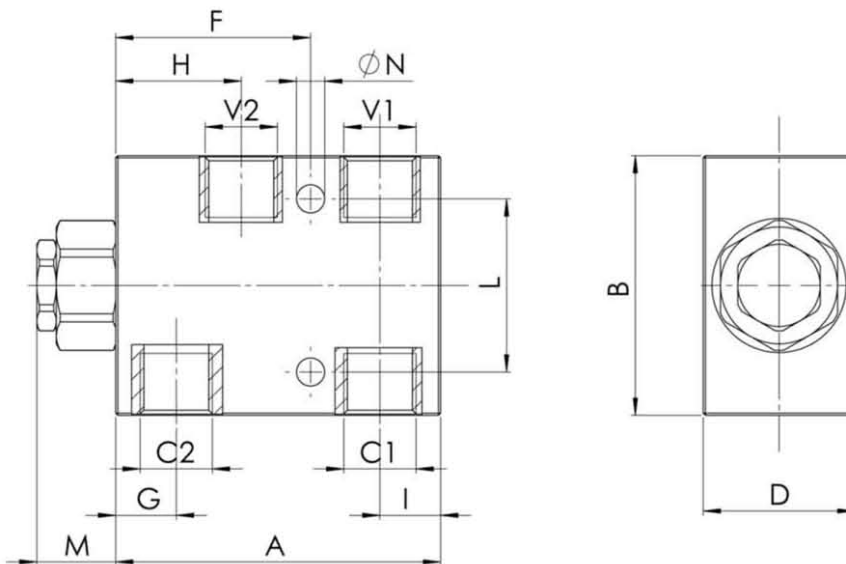

TIPO TYPE	PORTATA MAX. FLOW	PRESSIONE MAX. - MAX. PRESSURE (S=CORPO IN ACCIAIO, S=STEEL BODY)	V1-C1 V2-C2	A	B	D	F	G	H	I	L	M	N	PESO WEIGHT
	l/min	bar	BSPP	mm	mm	mm	mm	mm	mm	mm	mm	mm	mm	Kg
FPS L 3/8	30	210 - 350 (S)	3/8"	75	60	35	45	14	29	14	40	18.5	6.5	0.480
FPS L 1/2	45	210 - 350 (S)	1/2"	95	70	35	55	21	38	19	40	15	8.5	0.620
FPS L 3/4	85	210 - 300 (S)	3/4"	135	90	50	80	30	57.5	22	50	14	10.5	1.650

Queste valvole, data la loro configurazione, non consentono una elevata contropressione allo scarico
These valves, owing to their configuration - can't allow for a high discharge counterpressure

	FPS L 3/8	FPS L 1/2	FPS L 3/4
Rapporto di pilotaggio - Pilot ratio	1 : 7	1 : 3.5	1 : 4

ESEMPIO DI ORDINAZIONE - ORDERING CODE EXAMPLE

FPS L 3/8 2,5 G * *

Codice base
Basic code

Connessioni
Port sizes

3/8 - 3/8" BSPP
1/2 - 1/2" BSPP
3/4 - 3/4" BSPP *

Pressione apertura ritegno - Cracking pressure
Omettere se 2,5 bar
Indicare se 5 - 10 bar
Omit if 2,5 bar
Specify if 5 - 10 bar *

Guarnizioni - Seals
Omettere se BUNA-N
Omit if BUNA-N
* V=Viton

Materiale corpo: omettere se alluminio,
S=acciaio
Body material: omit if aluminium,
* S=steel

Con guarnizione sul pilota
With seal on pilot valve
Omettere se non richiesta
* Omit if not request